

TECHNICAL DATA SHEET

LU4CSAL67 - 3M Dual Lock™ / Aga-Led Type A

VERSION - 17.01.2017

STANDARD LUMINAIRE

Reference	LU4CSAL67
Mounting Plate	DLMP: 3M Dual Lock™ (see specifications)
Protection Class	IP67
Lighting Source	Aga-Led® Type A
Connector	Festoon on B'Light conductor 16mm ²
Standard Dimensions	330 x 43 x Ht.35mm
Length on measure	on request up to 1025 mm
Nb Lighting Unit	4 LEDs for standard luminaire
Voltage	24V
Power	4 W
Connecting Cable	One side: 20cm cable PUR 2x0.75mm ²
End Caps	EU4E + Rotule 8mm

APPLICATION: FACADE - ARCHITECTURAL ORNEMENT ORIENTABLE DOWN-LIGHTING LUMINAIRE



FINISH

Standard Color Finishing Profil : Natural Anodised Aluminium

On request
 Thermo-enameling
 Powder Coating RAL
 Color Anodising
 Polished Aluminium Chrome Aspect
 Polished Aluminium Gold Aspect

Standard Cover Finishing : VRC-Clear Glass

On request
 VRM-Opaline Glass

ON REQUEST

Connecting Plug	AMSP / AFP
Dimming Option	1-10V, Dali, KNX Ask technical departement for more information

LIGHTING SOURCE

Lighting Source	Aga-Led® Type A
Ref	A10
Voltage	24V
Power	1W
Beam Angle	15°
CRI	80
Light Output	lm/Unit
	2800K 40lm
	4000K 45lm
Lifetime	60'000h - 5 years
Working T°	-30°C ~ +55°C

CERTIFICAT

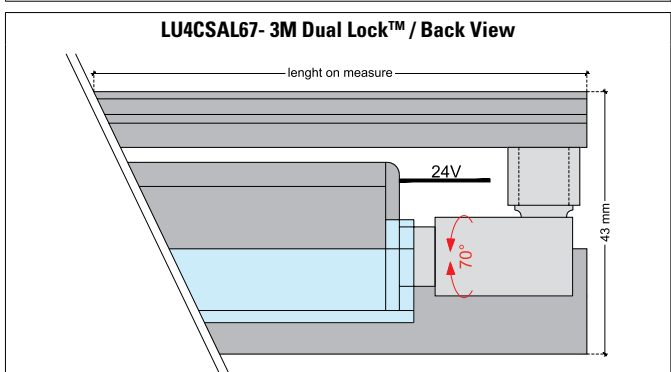
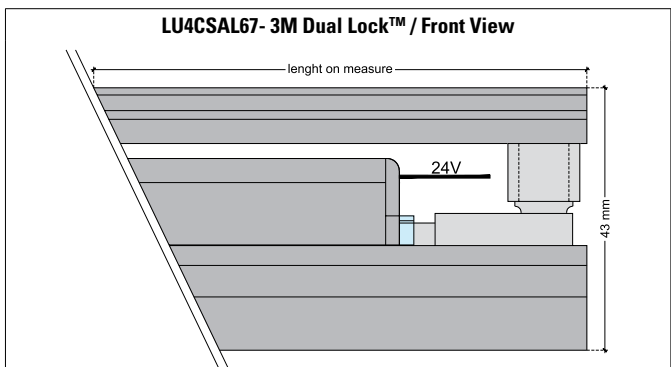
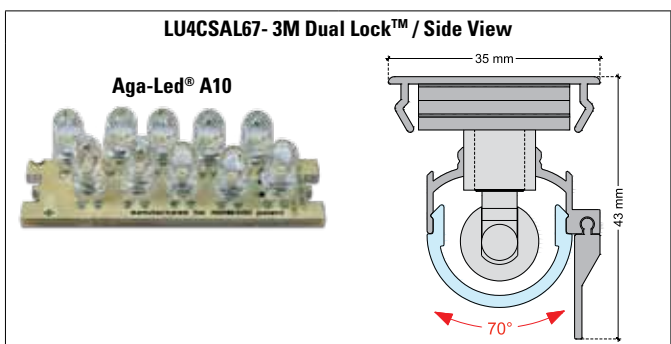

On Request: Connecting Plug AMSP/AFP



TECHNICAL DATA SHEET
Mounting Plate : 3M Dual Lock™

VERSION - 17.01.2017

3MDualLock™ sont des fermetures-pressions flexibles et autocollantes. La liaison s'effectue par simple pression de deux de ces éléments de sorte que les petites têtes s'encastrent les unes dans les autres.

Utilisations 3M Dual Lock™:

- Pour des fixations et des fermetures qui doivent s'ouvrir et se refermer
- 3M Dual Lock™ peut remplacer des systèmes conventionnels comme vis, rivets, clips aimants,....
- Fixation pour éléments qui doivent être enlevés et remis facilement pour échanger des pièces, pour l'entretien ou la réparation.

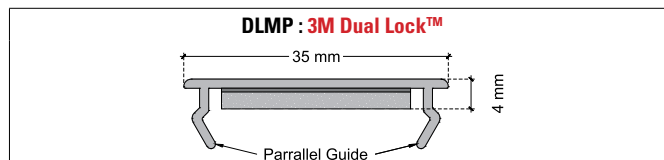

SPECIFICATIONS

Référence	DLMP : 3M Dual Lock™
Mounting Plate	CRPS
Standard Dimensions	330 x 35 x Ht.4mm
Lenght on measure	on request up to 3000mm
Round Heads	40 / cm ²
Working T°	-30°C ~ +70°C

FINISH

Color Finishing Mounting Plate

Standard	Natural Anodised Aluminium
On request	Thermo-enameling
	Powder Coating RAL
	Color Anodising
	Polished Aluminium Chrome Aspect
	Polished Aluminium Gold Aspect

Dual Lock Finishing

Standard	Black
----------	-------